

GÖLZ®



Core drilling

www.goelz.de

Dry drilling with and without dust extraction for switches and junction boxes

Electric hand-held core drill T1800-82
drill range up to 90 mm

Especially for the electrical and sanitary installations.

Handy single speed drill for electric installation holes Ø 68, 82, 102, 112 mm.

Vibration-free working.

Dry drilling in soft bricks, as sandstone, lime, aerated concrete and clinker bricks.

Dry operation with and without dust extraction.



Technical data - extant of delivery

- power 1,8 kW; 230 V
- spindle connection M18x2,5
- 1 speed drill gear, speed range 1300 rpm
- carrying case included

GÖLZ T1800-82		1 speed gear
Type	Technical data	Speed range
T1800-82 drill range 30-90 mm	Dry drilling machine with spade and additional handle, 230V, 1800 Watt, multifunctional electronic, spindle connection M18x2,5, Weight 4,6 kg, incl. transport box	1300 rpm

machine

T1800-82 FB20EL

precise drilling - professional solutions
percussion-free • vibration-free

Electric hand-held core drill machine FB20EL

drill range - wet up to 152 mm

drill range - dry up to 250 mm



Wet- and dry drilling in concrete and brickwork.

For hand held applications or rig mounted on KB110 or KB125.

Openings for cables, pipes and ventilations.
For precise anchor holes and core samples.

Technical data - extant of delivery

- 3-speed drill gear
- drill bit connection 1¼" UNC + R½"
- with PRCD switch for safe working during wet drilling
- carrying case included

GÖLZ FB20EL		3 speed gear
Type	Technical data	Speed range
FB20EL drill range wet 20-152 mm drill range dry 20-250 mm	Wet/Dry drilling machine with spade and additional handle, 230 V, 2000 Watt, multifunctional electronic, PRCD switch, collar 60 mm, multi purpose spindle 1 ¼" UNC + R½", weight 6,8 kg	485/1170/1780 rpm

For wet and dry drilling in concrete and masonry - hand held or rig mounted

Electric hand-held core drill EBM33F

drill range concrete up to 152 mm

drill range brickwork up to 162 mm

Wet and dry drilling in concrete and brickwork.

For hand-held applications or rig mounted on KB110 or KB125.

Openings for cables, pipes and for core samples.



Technical data

- 3 speed drill gear
- drill bit connection 1 ¼" UNC + R½"
- with PRCD switch for safe working during wet drilling

GÖLZ EBM33F		3 speed gear
Type	Technical data	Speed range
EBM33F drill range dry 15-152 mm drill range wet 20-162 mm	with pistol and additional handle, 230 V, 2000 Watt, PRCD safety switch, spindle connection 1 ¼" UNC + R½", Weight 5,2 kg	520/1400/2900 rpm

machine

EBM33F KB110, KB125

Lightweight aluminium drill rig for use with
hand-held drill motors

Technical data

- motor connection for hand-held drills (60mm)
- stepless angle drilling device up to 45°
- drilling range up to 162 mm
- laser pointer for easy fixing
- feed handle, left or right side use
- carrying handle
- tool kit



Drill rig KB125 with anchor/vacuum base



Drill rig KB110 with anchor/vacuum base

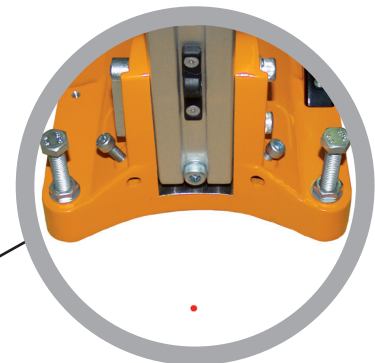

laser pointer

GÖLZ Drill rig KB110 & KB125

Technical data	Gözl KB110	Gözl KB125
Drill range:	Ø 10-152 mm	Ø 10-162 mm
Stroke:	450 mm	650 mm
Angle drilling up to 45°:	Yes	Yes
Fastening:	Vacuum-/anchor base	Vacuum-/anchor base
Dimensions (LxWxH):	310x255x890 mm	505x360x945 mm
Weight:	10 kg	12 kg



sliding roller for precise guiding of the drill carriage



transport handle

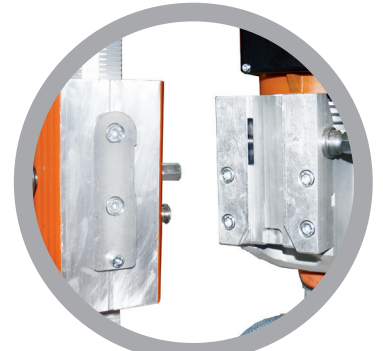

motor quick mount STS

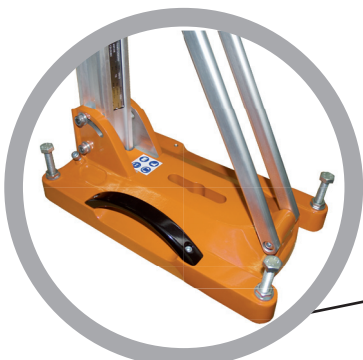

anchor/vacuum fixing base

machine

KB125

Universal and exact drill rig with integrated backrest



drilling motor with electronic overload protection and 36 month warranty



stepless angle drilling device up to 45°



laser pointer

Technical data

- light weight aluminium drill rig weighing only 12 kg
- stroke 600 mm
- stepless angle drilling device up to 45°
- motor quick mount STS
- feed handle, left or right hand operation
- laser pointer for easy fixing
- anchor/vacuum fixing base
- inclusive tool and fastening kit
- **optional accessories:** water tank, vacuum pump, vacuum-kit, water collecting ring

GÖLZ KB125		drill bit connection 1¼" UNC
Complete with electric motor		Speed range
T1-200EL drill range Ø 20-200 mm	230 V, 2,2 kW, 50 Hz, PRCD drill bit connection 1¼" UNC 3-speed	350/920/1280 rpm
T2-220EL drill range Ø 10-220 mm	230 V, 2,57 kW, 50 Hz, PRCD drill bit connection 1¼" UNC 3-speed	320/550/790 rpm
drill rig KB125	vacuum/anchor fixing base with motor quick mount STS and tool set (without fixing set), weight 12 kg,	

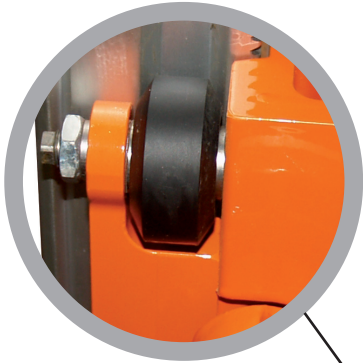

sliding rollers for precise guiding of the drill carriage



transport handle

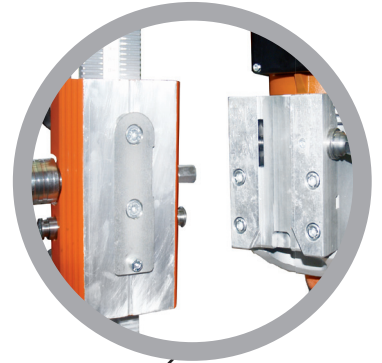

motor quick mount STS

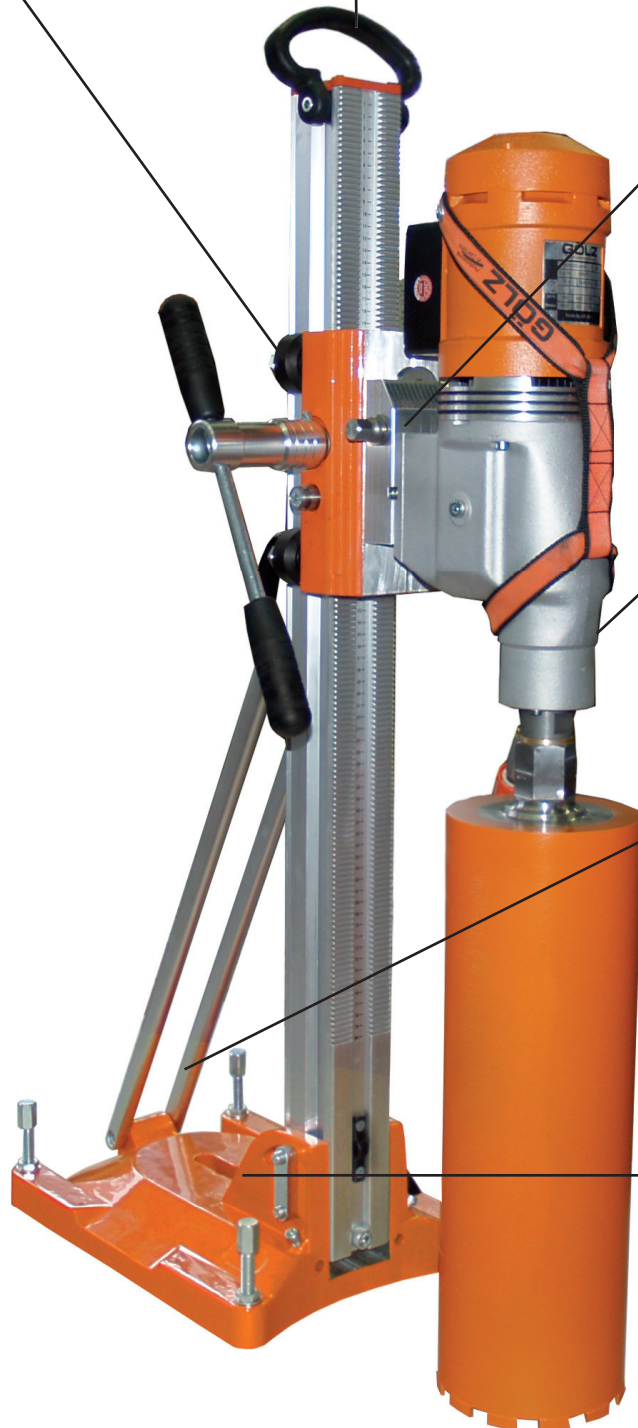

machine

KB250

Professional core drilling machine in aluminium light weight construction

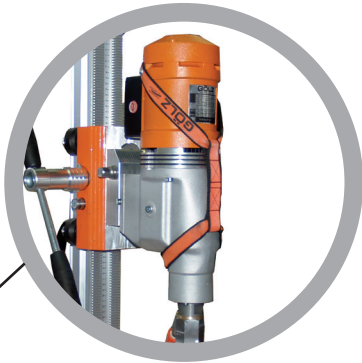

drill motor options
BBM33L extra or
T9-350

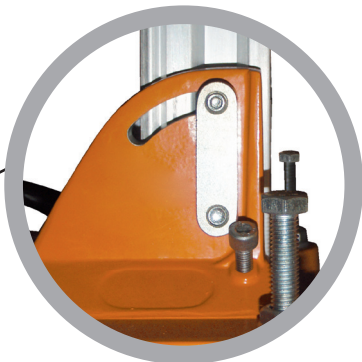

stepless angle drilling
device up to 45°



anchor/vacuum fixing base

Technical data

- stroke 650 mm
- vacuum/anchor fixing base
- motor quick mount STS
- 2 speed feeding with a 1:4 reduction gear box
- stepless angle drilling device up to 45°
- feed handle, left or right hand operation
- laser pointer shows the drill centre for easy fixing and exact drilling
- inclusive tool and fixing set
- weight: 15,5 kg
- **optional accessories:** water tank, vacuum pump, vacuum-kit, water collection ring

GÖLZ KB250

drill bit connection 1¼" UNC

complete with electric motor		speed range
T9-350 electric motor drill range Ø 25-300 mm	230 V, 3,2 kW, 50-60 Hz PRCD drill bit connection 1¼" UNC 4-speed	200/325/565/1015 rpm
BBM33L extra electric motor drill range Ø 50-300 mm	230 V, 3,3 kW, 50 Hz, PRCD drill bit connection 1¼" UNC 3-speed	180/430/750 rpm
drill rig KB250	vacuum/anchor fixing base with motor quick mount STS and tool set (without fixing set), reduction gear box, weight 15,5 kg	

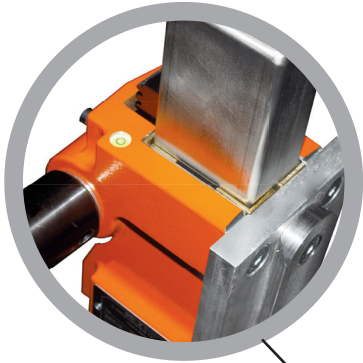

precise sliding of the drill carriage



stainless steel drill column

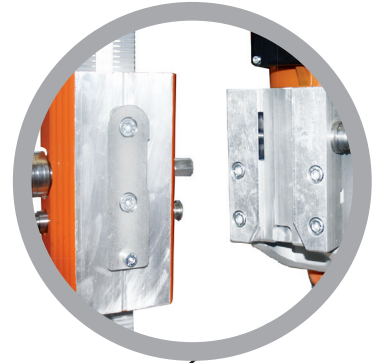

motor quick mount STS



machine

KB130

The complete set up for the construction site
unpack - fasten - drill



drill motor options
T1-200 / T2-220 / T9-350



stepless angle drilling
device up to 45°

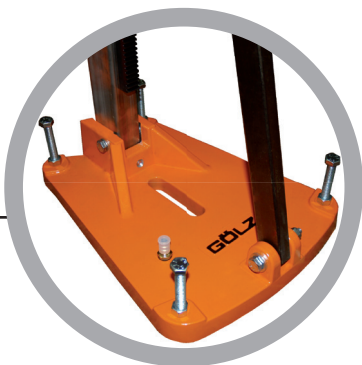

anchor/vacuum fixing base

Technical data

- stroke 700 mm
- motor quick mount STS
- stepless angle drilling device up to 45°
- feed handle, left or right hand operation
- tool and fixing set
- weight drill rig: 17 kg
- **optional accessories:** water tank, vacuum pump, vacuum-kit, water collection ring

GÖLZ KB130		drill bit connection 1¼" UNC
complete with electric motor		speed range
T1-200EL electric motor drill range Ø 20-200 mm	230 V, 2,20 kW, 50 Hz, PRCD drill bit connection 1¼" UNC 3-speed	350/920/1280 rpm
T2-220EL electric motor drill range Ø 35-220 mm	230 V, 2,57 kW, 50 Hz, PRCD drill bit connection 1¼" UNC 3-speed	320/550/790 rpm
T9-350 electric motor drill range Ø 50-280 mm	230 V, 3,0 kW, 50 Hz, PRCD drill bit connection 1¼" UNC 4-speed	200/325/565/1015 rpm
drill rig KB130	vacuum/anchor fixing base with motor quick mount STS and tool set (without fixing set), weight 17 kg	



extra stable stainless steel double-column



carriage fine-feeding by hand crank

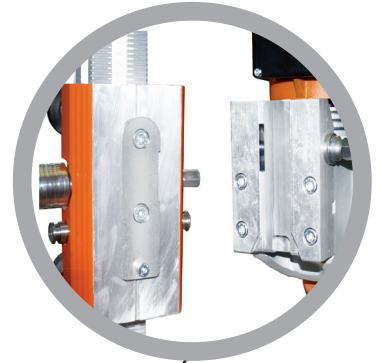

motor quick mount STS



Multipurpose core drilling machine for the sewer and building industry



converting kit for sewage drilling with self centring frame

Technical data

- standard equipment "wall and ceiling" with dowel fixing base
- stroke 630 mm
- double column with fine feeding carriage
- motor quick mount STS
- 2 backride support
- tool and fixing set
- weight drill rig: 27 kg
- **optional accessories:** vacuum suction plate, water collection ring, vacuum pump, water tank, stepless angle drilling, sewage converting kit

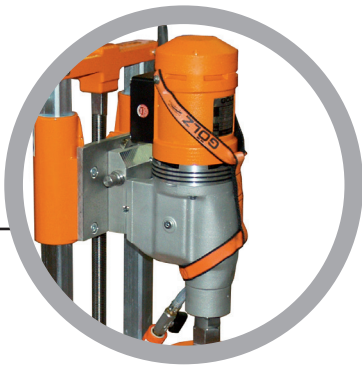

drill motor options electro, hydraulic, gasoline, air

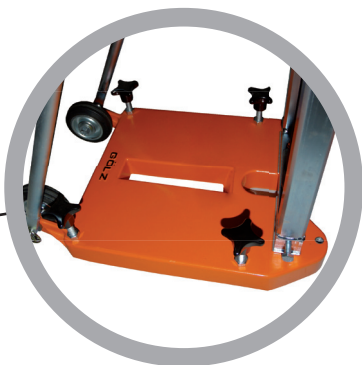

stable anchor fixing base

GÖLZ KB150		drill bit connection 1¼" UNC
complete with electric motor		speed range
T9-350 electric motor drill range Ø 50-300 mm	230 V, 3,2 kW, 50-60 Hz, PRCD drill bit connection 1¼" UNC 4-speed	200/325/565/1015 rpm
BBM33L extra electric motor drill range Ø 30-300 mm	230 V, 3,3 kW, 50 Hz, PRCD drill bit connection 1¼" UNC 3-speed	180/430/750 rpm
complete with gasoline motor		speed range
STIHL 2-stroke-motor drill range Ø 110-300 mm	2,8 kW drill bit connection Gölz 3-hole flange	300 rpm
complete with air motor		speed range
LZL15 air motor drill range Ø 30-300 mm	2,4 kW, air consumption 3,3 m ³ ,	600 rpm 280 rpm
complete with hydraulic motor		speed range
HBM50 hydraulic motor drill range Ø 50-150 mm	4,5 kW, oil consumption 30 l/min, 140 bar	610 rpm
HBM100 hydraulic motor drill range Ø 150 - 300 mm	4,5 kW, oil consumption 30 l/min, 140 bar	300 rpm
HBM160 hydraulic motor drill range Ø 250 - 333 mm	4,5 kW, oil consumption 30 l/min, 140 bar	190 rpm

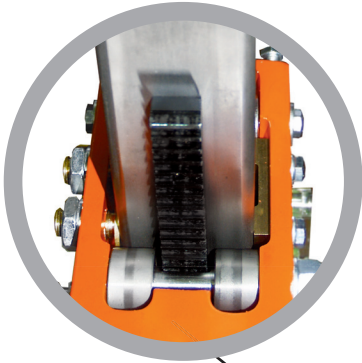

drill carriage guided by precise and wear resistant combined slide/roller bearings



stainless steel column



motor quick mount STS

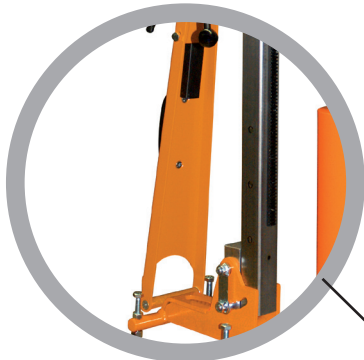

back support optional in accessories

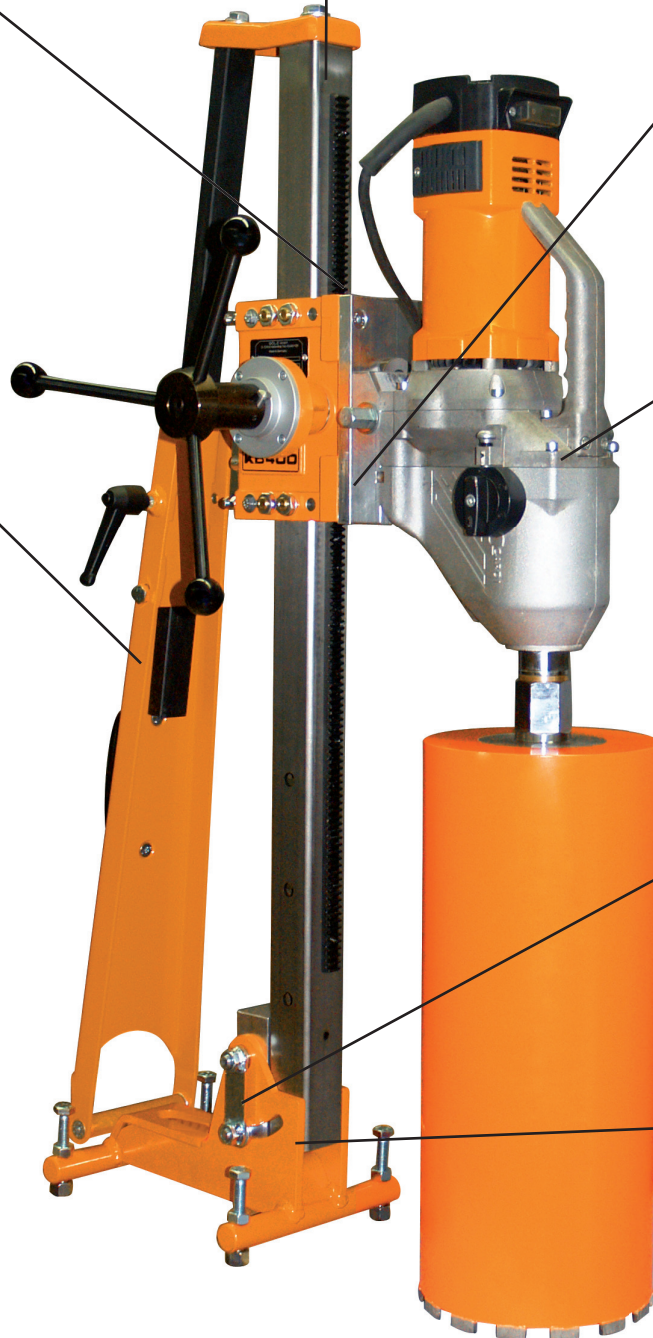

Core drilling machine with easy running and long life drill carriage for the professional user



optionally with electric or hydraulic motor

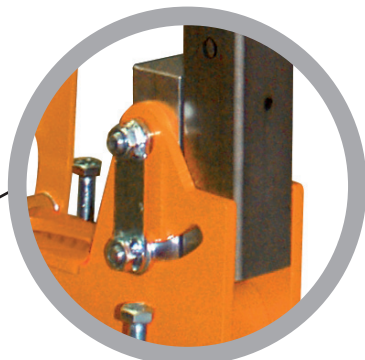

stepless angle drilling device up to 45° + negative drilling possible

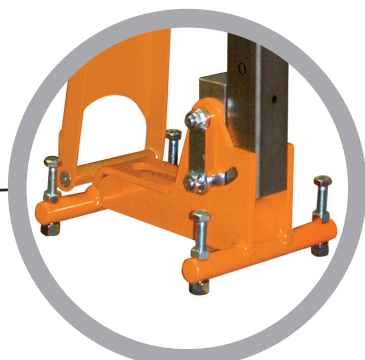

anchor fixing base

Technical data

- stroke 600 mm
- drill carriage guided by combined slider/roller bearings
- motor quick mount STS
- 2 speed feeding with a 1:4 reduction gear box
- feed handle, left or right hand operation
- stepless angle drilling device up to 45°
- negative drilling possible
- tool and fixing set
- weight drill rig: 17,5 kg
- **optional accessories:** wheel set, bormatic, backride support

GÖLZ KB400		drill bit connection 1¼" UNC
complete with electric motor		speed range
T9-350 electric motor drill range Ø 350 mm	230 V, 3,2 kW, 50 Hz, PRCD drill bit connection 1¼" UNC 4-speed	200/325/565/1015 rpm
T9-475 electric motor drill range Ø 400 mm	230 V, 3,42 kW, 50 Hz, PRCD drill bit connection 1¼" UNC 4-speed	165/315/515/1200 rpm
BBM33L extra electric motor drill range Ø 400 mm	230 V, 3,30 kW, 50 Hz, PRCD drill bit connection 1¼" UNC 3-speed	180/430/750 rpm
Dolphin DX5L drill range Ø 400 mm	400 V, 5,2 kW, 50 Hz drill bit connection 1¼" UNC 3-speed	120/280/440 rpm
complete with hydraulic motor		speed range
HBM160 hydraulic motor drill range Ø 250-400 mm	oil consumption 30 l/min, 140 bar drill bit connection 1¼" UNC, 1-speed	190 rpm
drill rig KB400	anchor fixing base with motor quick mount STS and tool set (without fixing set), reduction gear box, weight 17,5 kg	



drill carriage guided by precise and wear resistant combined slide/roller bearings



stainless steel column



motor quick mount STS

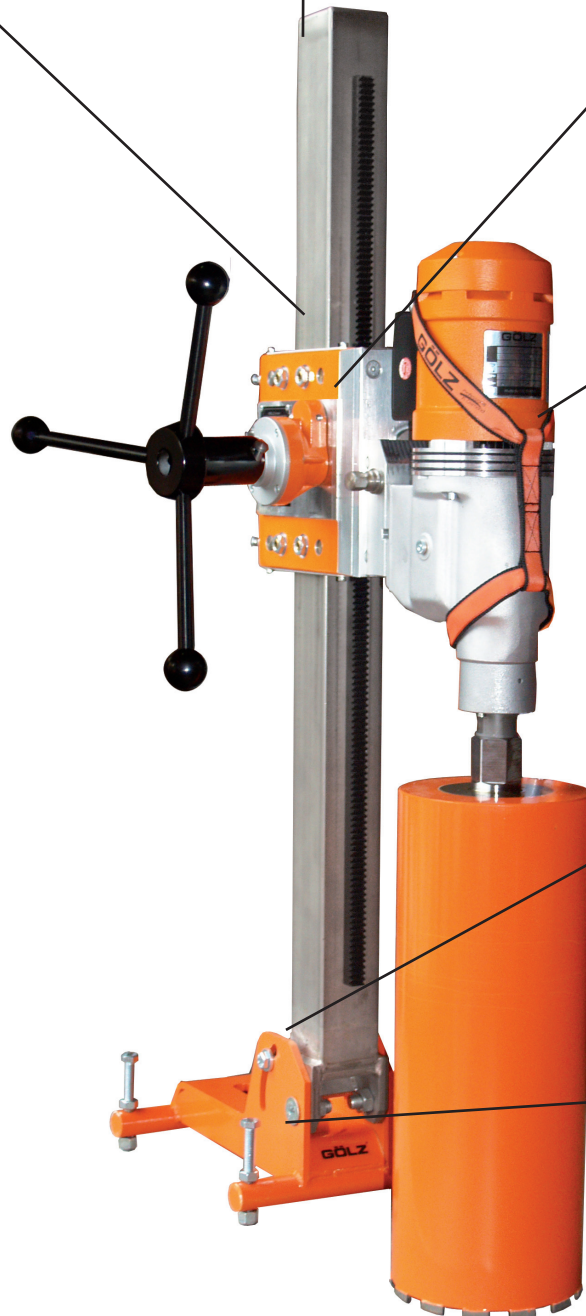

machine

KB500

Core drilling machine with easy running and long life drill carriage for the professional user

Technical data

- stroke 800 mm
- drill carriage guided by combined slider/roller bearings
- motor quick mount STS
- 2 speed feeding with a 1:4 reduction gear box
- feed handle, left or right hand operation
- stepless angle drilling device up to 45°
- negative drilling possible
- tool and fixing set
- weight drill rig: 26 kg
- **optional accessories:** extension column for deep-drilling, backside support and BorMatic



optionally with electric or hydraulic motor

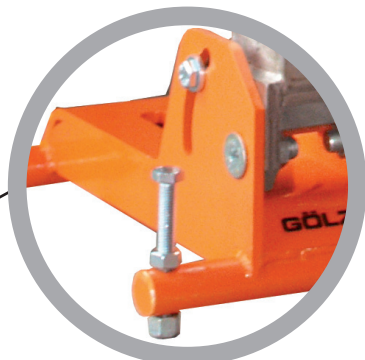

stepless angle drilling device up to 45° + negative drilling up to 15° possible

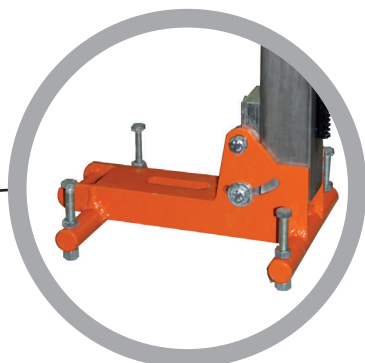

anchor fixing base

GÖLZ KB500		drill bit connection 1¼" UNC
complete with electric motor		speed range
T9-475 electric motor drill range Ø 100-500 mm	230 V, 3,42 kW, 50 Hz, PRCD drill bit connection 1¼" UNC 4-speed	165/315/515/1200 rpm
Dolphin DX5L drill range Ø 100-500 mm	400 V, 5,2 kW drill bit connection 1¼" UNC 3-speed	120/280/440 rpm
complete with hydraulic motor		speed range
HBM200 hydraulic (only with backrest) drill range Ø 400-600 mm	oil consumption 30 l/min, 140 bar, drill bit connection 1¼" UNC, 1-speed	150 rpm
drill rig KB500	anchor fixing base with motor quick mount STS and tool set (without fixing set), reduction gear box, weight 26 kg	

Accessories for GÖLZ Automatic core drilling

Ideal for use in:

- Increased productivity through simultaneous use of two or more devices by an operator
- Drills faster than manual feed
- Longer life of diamond drill bit due to constant feed pressure
- Low load of the drill motor with constant feed pressure (no load peaks)

GÖLZ BorMatic80



Features:

- Drills fully automatically without operator
- 5 different feed adjustments possible
- When the hole is complete the BorMatic turns on automatically
- Automatic reduction of the feed in steel
- without tools mounting on GÖLZ KB400 KB500 + in connection with BBM33L-extra drill motor
- Compact size
(LxWxH): 166x195x275 mm
- Weight: only 6.3 kg



BorMatic80

Type

Bormatic80, 230 V, 50 Hz, 52,8 Watt, working temperature of – 5° bis + 40° C, Weight 6,3 kg

machine

BorMatic

GÖLZ KB400 and KB500 drilling up to Ø 500 mm



Ideal for use in:

- series or perforation holes for large openings (doors, windows, circular holes for spiral staircases, etc.)
- series drilling for various mounting holes such as bridge railings, or in steel construction
- holes with large depth and a long column (anchor holes in the renovation)
- Allows the operator to run several drill rigs, within sight, at the same time.

GÖLZ BorMatic750



Features:

- Drills fully automatically without operator
- 16 different feed adjustments possible
- When the hole is complete the BorMatic turns on automatically
- Automatic reduction of the feed in steel
- For use from small to large drilling diameters
- without tools mounting on GÖLZ KB400 KB500 + in connection with BBM33L-extra drill motor
- (LxWxH): 248x189x280 mm
- Weight: only 8,2 kg

BorMatic 750

Type

Bormatic 750, 230 V, 50 Hz, 75 Watt, working temperature of – 5° bis + 40° C, Weight 8,2 kg



STIHL gasoline engine
2,8 kW / 3,8 PS
2-stroke



ergonomic handles for one-man
operation



incl. water tank 10 litre

Quickly useable hand held core drill machine for pipe drilling

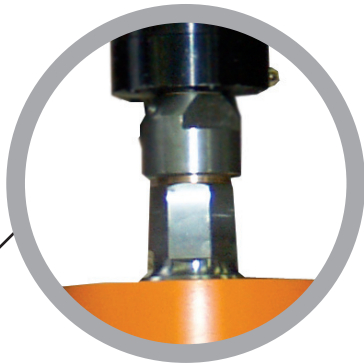

optional with 3-hole or 1¼" UNC drill bit connection

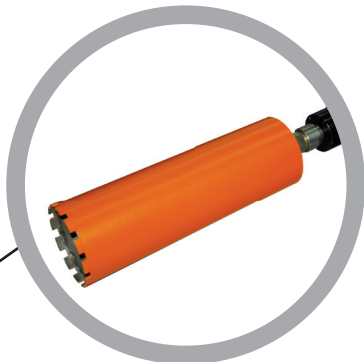

drill range up to 200 mm

Technical data

- one man operation - unproblematic and quick usage
- in fact of the position independant STIHL-2 stroke engine this machine is quickly useable on any construction site without need of any power supply systems
- drilling range 50-200 mm
- drill bit connection GÖLZ 3-Loch (optional with 1¼" UNC drill bit connection)
- integrated water swivel
- pressurized water tank, 10 l with hose, allows cooling of the drill bit with water
- 2,8 kW (3,8 PS)
- speed range 600 min⁻¹
- dimension (LxWxH): 339x468x589 mm
- weight: 24 kg (without drill bit)

GÖLZ FB200		drill bit connection 1¼" UNC
complete with motor		speed range
Stihl 2-stroke-motor drill range Ø 50-200 mm	2,8 kW (3,8 PS) drill bit connection GÖLZ 3-hole- flange / optional 1¼" UNC (incl. water tank)	600 rpm



10 l pressurized water tank



4 metre exhaust gas hose



motor options:
gasoline, electric or air motor

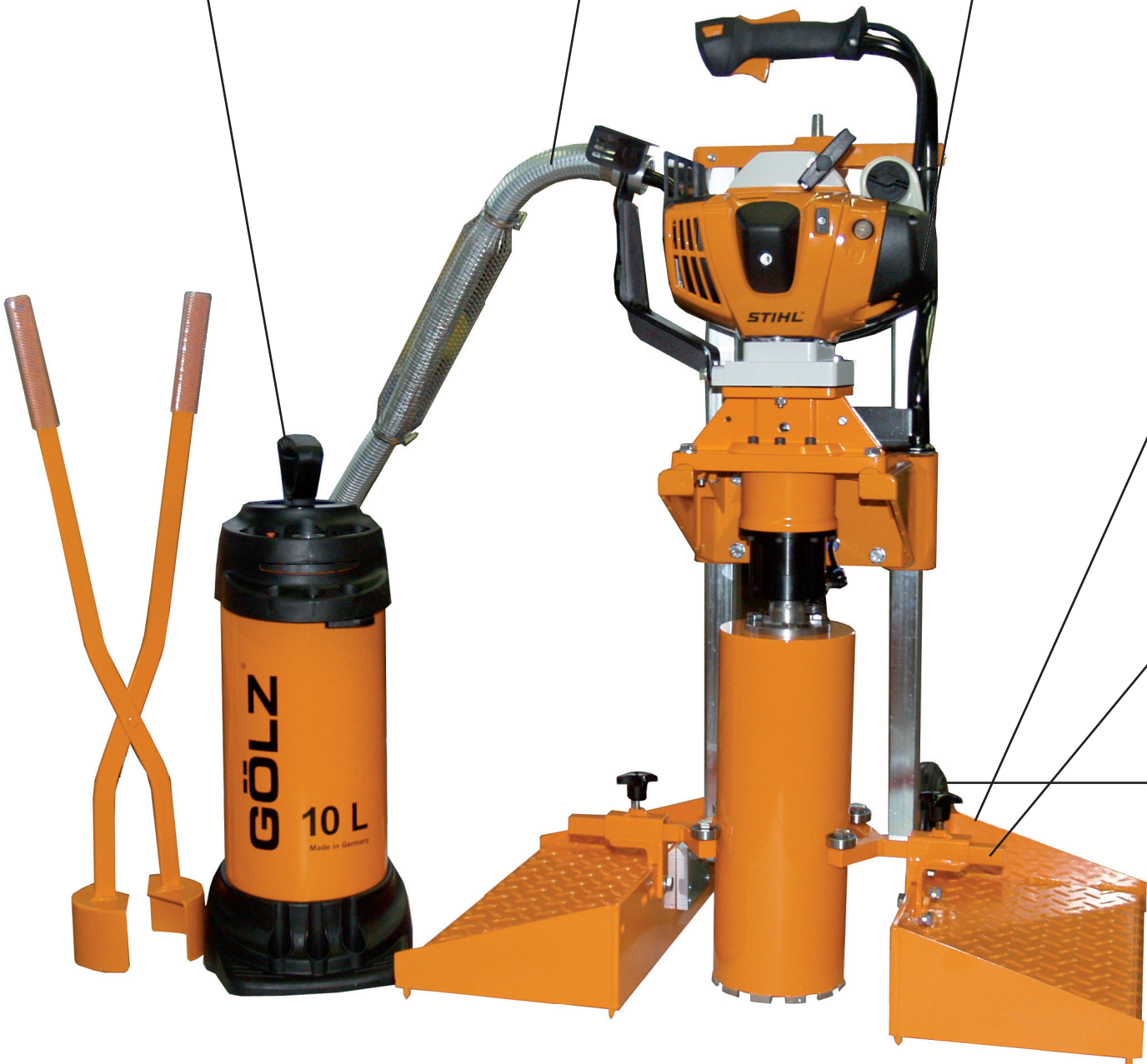

Specially designed core drilling machine for the road construction

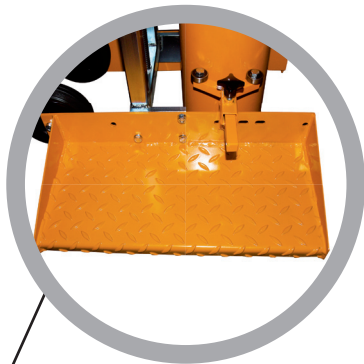

standing plates

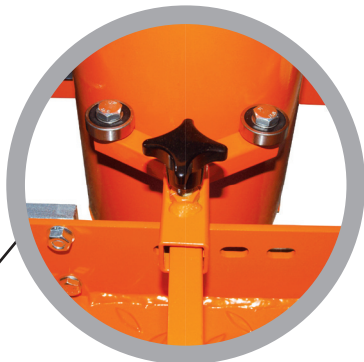

roller guides for exact centring of the drill bit

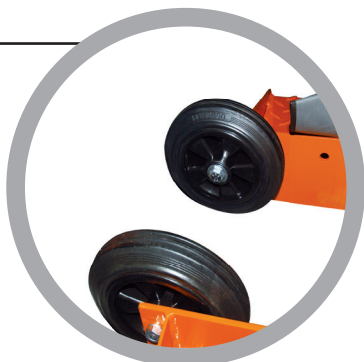

transport wheels for easy loading / manoeuvring

Owing to its compact and in fact of the complete equipment standard set the KB200 can be used quickly and unproblematically for:

- core sampling in asphalt and concrete pavements
- drilling out of gate valves
- coring to place snubbing posts and different types of bollards
- openings for airfield lighting
- coring to place crash barriers or fences

Technical data - extent of delivery

- stroke 630 mm
- Twin column drill rig with standing plates and roller guides
- pressurized water tank 10 l, with hose for supplying the drill bit with flushing water
- exhaust gas hose, 4 m long, to deflect fumes from the working area
- Tool set
- Weight with STIHL 2-stroke-engine: 53 kg

GÖLZ KB200		Gözl 3-hole flange / 1¼" UNC
complete with gasoline motor		speed range
Stihl 2-stroke-motor drill range Ø 107-200 mm	2,8 kW (3,8 HP) drill bit connection Gözl 3-hole-flange	600 rpm
complete with electric motor		speed range
T9-350 electric motor drill range Ø 50-290 mm	230 V, 3,0 kW, 50 Hz drill bit connection 1¼" UNC 4-speed	225/365/630/1000 rpm
complete with air motor		speed range
LZL15 air motor drill range Ø 107-200 mm	2,4 kW, air consumption 3 m³/min	600 rpm



4 metre exhaust gas hose



optional with electric, air, hydraulic or gasoline motor



self centering pipe

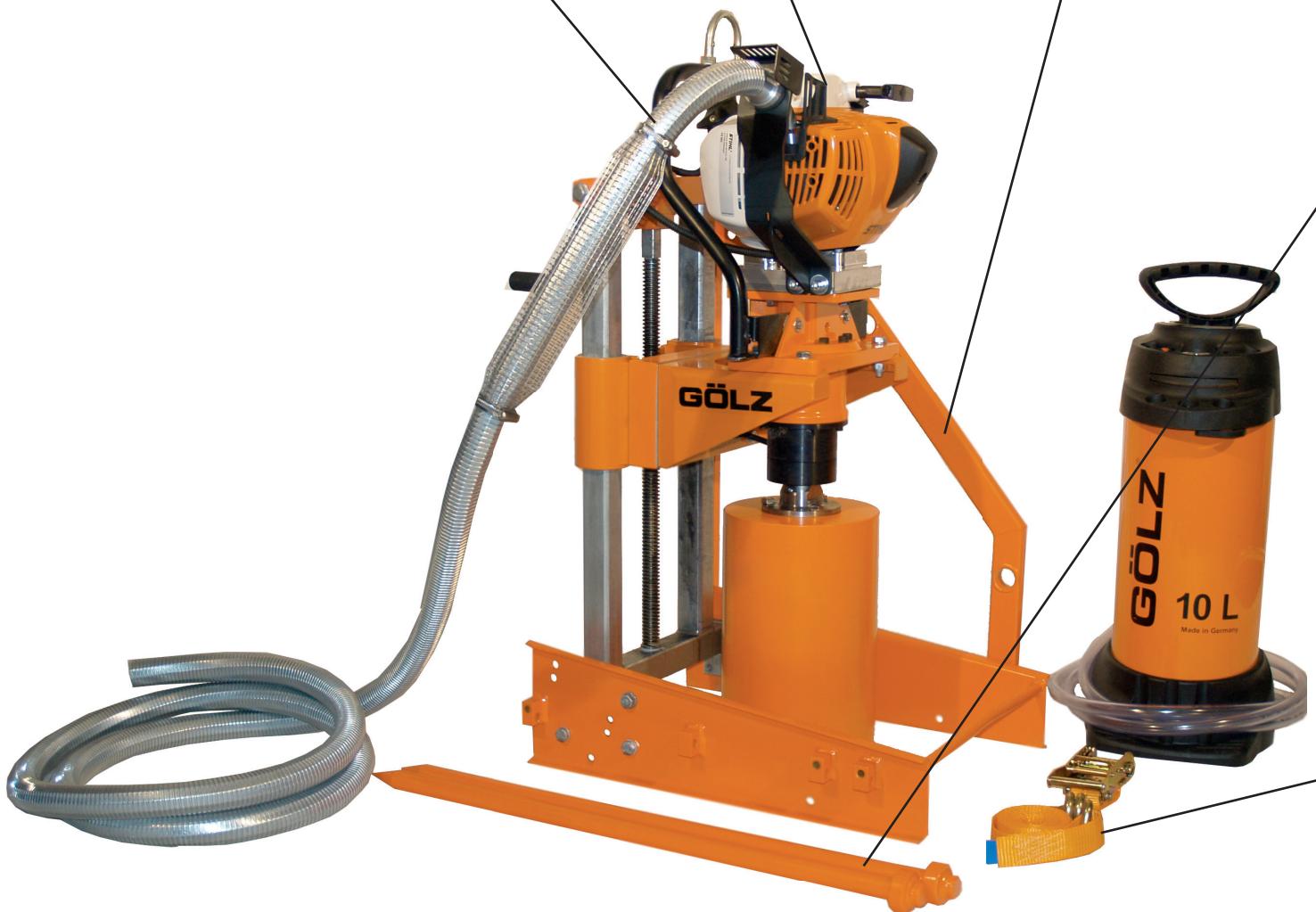

machine

KB300 KB350

The original pipe and sewage drilling machine up to Ø 354 mm

Technical data

Standard-equipment/extent of delivery for pipe-drilling:

- drill rig, stroke 450 mm, self centring pipe frame for 90°- or 45°-connection holes
- ground frame with 2 ground spikes for fixing the machine in the construction trench
- fastening strap 2,1 m with clamping ratchet for fixing directly on sewage pipe
- STIHL 2-Takt-gasoline engine, 2,8 kW (3,8 HP) – enabling independent use from any power supplying system
- exhaust gas hose, 4 m long, to deflect fumes from the working area
- gear box with swivel, drilling range 110-290/354 mm
- drill bit connection, GÖLZ 3-hole flange
- pressurized water tank 10 l, with hose for supplying the drill bit with flushing water
- Weight: 45 kg

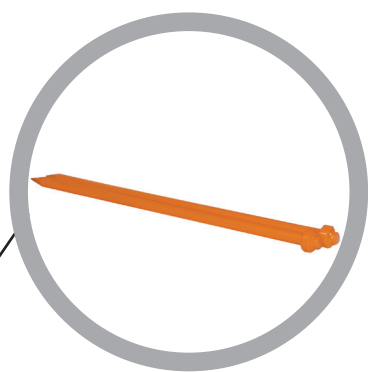

ground spikes for fixing in the ground on the construction site

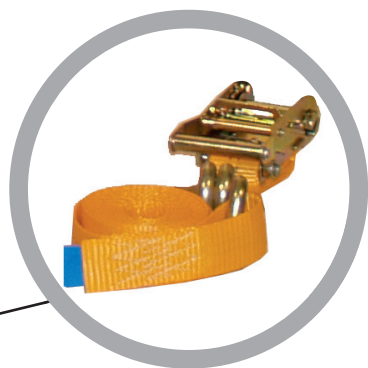

fastening strap with clamping ratchet

GÖLZ KB300		Gözl 3-hole flange / 1¼" UNC
complete with gasoline motor		speed range
STIHL 2-stroke-motor drill range Ø 110-290 mm	2,8 kW (3,8 HP) drill bit connection Gözl 3-hole-flange	300 rpm
complete with electric motor		speed range
T9-350 electric motor drill range Ø 110-290 mm	230 V, 3,0 kW, 50 Hz drill bit connection 1¼" UNC, 4-speed	200/325/565/1015 rpm
complete with air motor		speed range
LZL15 air motor drill range Ø 110-290 mm	2,4 kW, air consumption 3 m ³ /min drill bit connection 1¼" UNC	280 rpm
complete with hydraulic motor		speed range
Hydraulic motor drill range Ø 110-290 mm	4,5 kW, oil consumption 30 l/min, 140 bar, drill bit connection 1¼" UNC	300 rpm
GÖLZ KB350		Gözl 3-hole flange / 1¼" UNC
complete with gasoline motor		speed range
STIHL 2-stroke-motor drill range Ø 110-354 mm	2,8 kW (3,8 PS) drill bit connection Gözl 3-hole flange	300 rpm
complete with electric motor		speed range
T9-350 drill range Ø 50-354 mm	230 V, 3,0 kW, 50 Hz drill bit connection 1¼" UNC, 4-speed	200/325/565/1015 rpm
complete with air motor		speed range
LZL15 air motor drill range Ø 110-290 mm	2,4 kW, air consumption 3,3 m ³ , drill bit connection 1¼" UNC	280 rpm
complete with hydraulic motor		speed range
Hydraulic motor drill range Ø 110-290 mm	4,5 kW, oil consumption 30 l/min, 140 bar, drill bit connection 1¼" UNC	300 rpm



Vacuum pump C10

with safety-tank and check valve
suction volume: 115 l/min
tank capacity: 10 l
230 V, 0,75 kW, 50 Hz, 1400 rpm, IP44
weight 27 kg
dimensions (LxBxH): 340x360x620 mm
0295 010 0030



Vacuum kit, consisting of vacuum wedge and vacuum rubber

for KB110
0295 110 0012

for KB125
0295 125 0008

for KB250
0295 250 0050

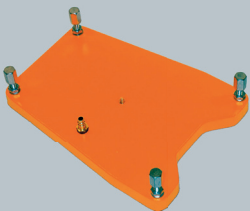

Vacuum plate

for KB130/250/400 anchor version up to max. Ø 200 mm
0295 230 0500

KB150 with quick connector
0295 150 0003



WB40E water tank

with electric pump and 12 V battery.
40l impact proofed tank pump with pressure regulation up to 4,5 bar.
Full battery charge up to 8 hours.
Incl. battery charger.
GARDENA-house coupling
0295 150 0190



Pressurized water tank

10l capacity incl. gauge and 4 m water hose for KB200, KB300, KB350
with brass-hose coupling
0295 010 0020

for GÖLZ-electric core drilling machines with GARDENA-hose coupling
0295 010 0021

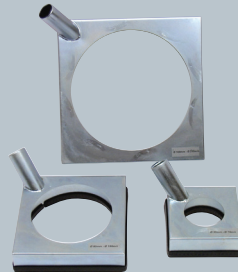

Water collection ring

self-priming by industrial vacuum cleaner.
up to Ø 70 mm
0295 150 0011

up to Ø 150 mm
0295 150 0019

up to Ø 250 mm
0295 150 0022

up to Ø 350 mm
0295 150 0038

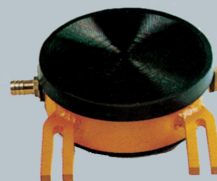

Water collection ring

for the draining of flushing water in connection with wet vac
KB130, max. Ø 112 mm
0295 130 0020

KB130, max. Ø 162 mm
0295 130 0021



Support rod

Quick fastening for drill rigs,
for clamping between floor and ceiling, or from wall to wall,
Range from 1.80 to 3.00 m
0295 130 0030



Reduction gear handle

with 2 feed ranges/direct/reduction 1:4
for KB250/400/500
0295 000 0840



Motor quick mount STS

Drill motor mounting plate for use with all GÖLZ STS mounting rigs
0295 110 0042



Submersible pump

portable, for core drilling with water supply from water barrel.
220 V, 50 Hz
80 l/min 6,5 m height
1003 000 01



Dry vac ISC-ARD 1425

Compact vacuum cleaner, specially designed for working with power tools, space saving, 230V, 1400W, 25l, special plastic container, 2 large wheels, 2 guide rolls with brake, appliance sockets with automatic on/off switch, electromagnetic pulse filter cleaning, automatic vibrator
Line cord length 8 m
Size (LxWxH): 457x400x535 mm
Flexible suction hose: 8m
Rubber nozzle 23 cm
0295 150 0127



Wet vac GS70K

230 V, 50 Hz, 70 l capacity
2 engines with 1200 watt each, with impact proofed plastic container
0295 150 0302

Wet vac GS70S

230 V, 50 Hz, 70l capacity
2 engines with 1200 watt each, with stainless steel container
0295 150 0300



Centring device

for FB20EL hand held machine

up to Ø -120 mm
0295 007 0080

up to Ø - 200 mm
0295 007 0081

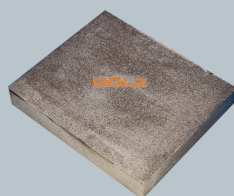

Abrasive sharpening block

to sharp retipped drill bits
dimensions (LxWxH)
350x260x50 mm
elastic
0268 180 0014



Fasteners

Rawl-dowel M12,
drill size up to -Ø 20mm
0263 370 0012

Wedge anchor M12,
drill-size-Ø 16 mm
0263 340 0014

Anchoing rod fitting for Rawl-dowel
250 mm long, M12 x 80
0267 120 0023

Anchoing rod fitting for wedge anchors 1
75 mm long, M12 x 30
0267 120 0024

Anchoing rod fitting for wedge anchors
250 mm long, M12 x 30
0267 120 0020



Nut
0267 120 0011

Washer
0295 000 0331

Quick release system

Anchoing rod with trapezoidal
thread 130 mm and threaded M12 x 35
0267 120 0030

Mounting kit complete

consisting of:
nut, washer, hammer drills SDS, 5 x 16 mm
spreader, Spindle bolt M12x160 mm
0295 110 0992

Secure mounting of core drilling by automatic subsequent expansion

Innovative bolt anchor concept
consisting of:

Expansion bolt Ø 16 mm
0263 340 0011

Spindle bolt
160 mm long, M12 inside
0267 120 0027

250 mm long, M12 inside
0267 120 0028

Spindle nut
0267 120 0019

Washer
0295 000 0331

Drill motor		Technical data				
T1800-82 	Type	Speed range rpm	Drill range	Power	Drill bit connection	Weight
	T1800-82	1300	Ø 30-90 mm	1,80 kW 230 V	M18x2,5	4,6 kg
EBM33F 	Type	Speed range rpm	Drill range	Power	Drill bit connection	Weight
	EBM33F	520/1400/290	Ø 15-152 mm wet Ø 20-162mm dry	2,0 kW 230 V	1¼" UNC +R ½"	5,2 kg
FB20EL 	Type	Speed range rpm	Drill range	Power	Drill bit connection	Weight
	FB20EL	485/1170/1780	Ø 20-152 mm wet Ø 20-250 mm dry	2,0 kW, 230 V	1¼" UNC + R ½"	6,8 kg
T1-200EL 	Type	Speed range rpm	Drill range	Power	Drill bit connection	Weight
	T1-200EL	350/920/1280	Ø 20-200 mm	2,20 kW 230 V	1¼" UNC	7,3 kg
EBL33 	Type	Speed range rpm	Drill range	Power	Drill bit connection	Weight
	EBL33	280/1200/2500	Ø 20-300 mm	2,30 kW 230 V	1¼" UNC	6,5 kg
T2-220EL 	Type	Speed range rpm	Drill range	Power	Drill bit connection	Weight
	T2-220EL	320/550/790	Ø 35-220 mm	2,57 kW 230 V	1¼" UNC	9,8 kg

Drill motor	Technical data					
<p>T9-350</p> 	Type	Speed range rpm	Drill range	Power	Drill bit connection	Weight
<p>BBM33L-extra</p> 	Type	Speed range rpm	Drill range	Power	Drill bit connection	Weight
<p>T9-475</p> 	Type	Speed range rpm	Drill range	Power	Drill bit connection	Weight
<p>HBM</p> 	Type	Speed range rpm	Drill range	Power	Drill bit connection	Weight
<p>Dolphin DX5L</p> 	Type	Speed range rpm	Drill range	Power	Drill bit connection	Weight

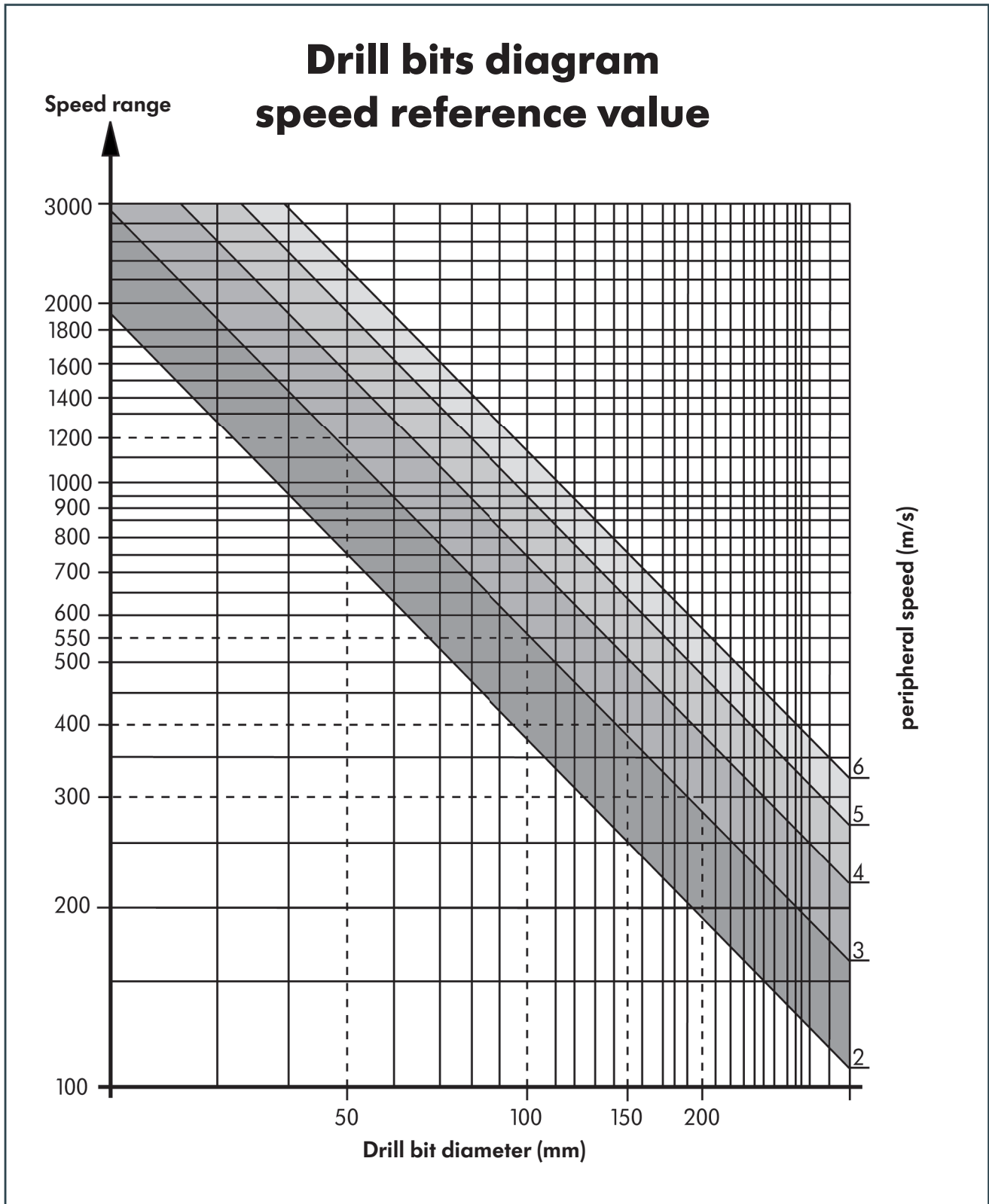

Optional peripheral speed
 in concrete and reinforced concrete
 in abrasive material (sand stone / asphalt)

2-4 m/sec
 4-6 m/sec

machine

GÖLZ®

GÖLZ®



Floor saw

www.goelz.de

GÖLZ®



**Tile saws - Masonry saws -
Block saws**

www.goelz.de

GÖLZ®



Slurry fox

www.goelz.de

GÖLZ®



Wire saw

www.goelz.de

GÖLZ®



GÖLZ GmbH

Postfach 26 | 53938 Hellenthal

Dommersbach 51 | 53940 Hellenthal-Blumenthal

Phone +49 (0) 2482 - 120 | Fax +49 (0) 2482 - 12 222

E-Mail info@goelz.de | Web www.goelz.de

